

ADVANTAGE UV BLACK

UV BLANKET

BENEFITS:

- Cord carcass offers excellent smash resistance and rapid recovery
- Optimal UV ink transfer
- Excellent dimensional stability
- Excellent for absorbent and non-absorbent materials
- Prevention of electrostatic charges
- High edge marking resistance
- Longer service life

NEW TECHNOLOGY

Cord carcass and EPDM carbon black face compound

| | |
|--------------------------|----------------------|
| COLOUR | Black |
| CONSTRUCTION | Cord carcass |
| TYPE | Compressible |
| SURFACE HARDNESS | 70 +/- 3 IRHD |
| STRETCH | < 0.70% @ 500 N/5 cm |
| NOMINAL THICKNESS | 1.95 mm (ISO 12636) |
| BOTTOM LAYER | Water/Solvent sealed |
| FACE COMPOUND | EPDM |

MAIN APPLICATION

| | |
|---------------------------|---|
| Sheetfed | ● |
| Packaging | ● |
| Coating | ● |
| Metal decorating | ● |
| Business forms and labels | ● |
| Heatset | ● |
| Coldset | ● |

● Recommended ● Suitable ● Not recommended

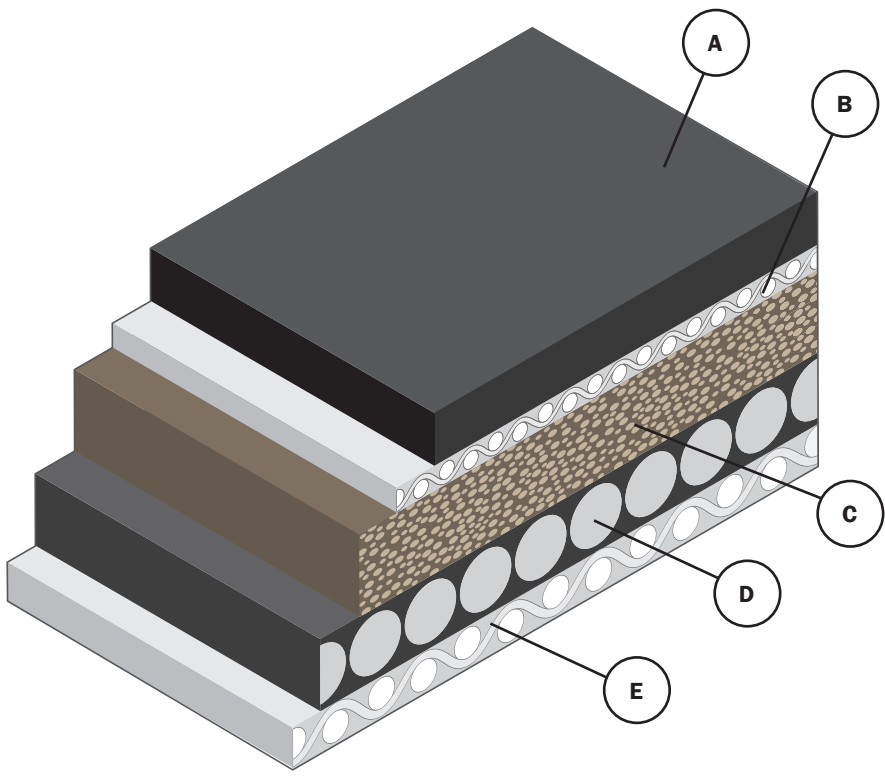

- A - Printing surface
- B - Fabric ply
- C - Closed-cell compressible layer
- D - Cord ply
- E - Sealed bottom fabric